



ATCNET TECHNOLOGY LIMITED

Deltapath 方案

目錄

1. Deltapath和Cisco

2. 逐步遷移

3. 一次性

你是否有一些END OF LIFE 和 END OF SUPPORT的思科話機



你的CUCM是否很久沒升級？

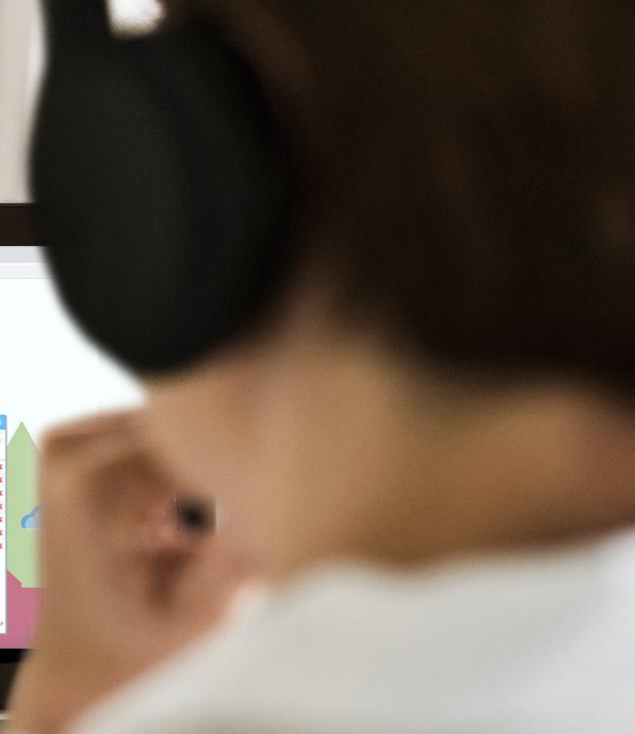
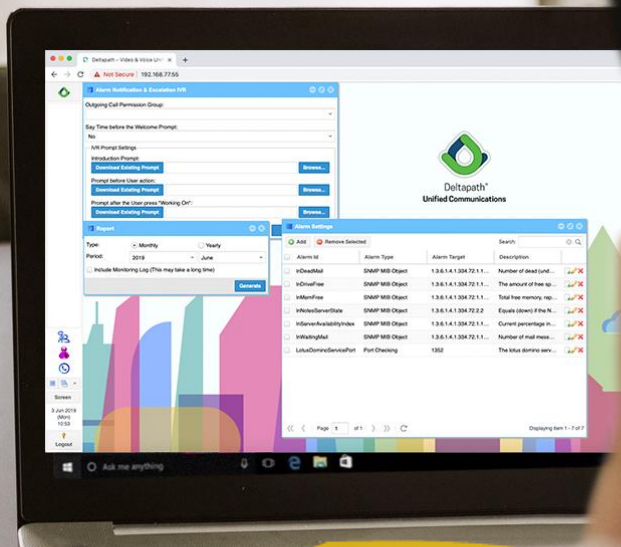

企業都希望最大限度的原有設備



DELTAPATH 平台對以下品牌型的話機做深度定制

FULL LINE OF POLYCOM ENDPOINTS:

**SoundPoint IP, VVX,
HDX, Group, RMX, Trio**

CISCO MODELS:

**3905, 3911, 3951, 6901, 6911,
6921, 6945, 6961, 7821, 7841,
7905, 7906, 7911, 7912, 7931,
7940, 7941, 7942, 7945, 7960,
7961, 7962, 7965, 7970, 7971,
7975, 8811, 8831, 8841, 8845,
8851, 8865, 8941, 8945, 9951,
9971, DX80, SX20**

AVAYA MODELS:

**4610SW, 4621SW,
9608, 9608G,
9611G, 9641G,
Scopia XT 4000 and
5000**

MITEL MODELS:

5312, 5340, 5330e

AUDIOCOCODES:

**310HD, 320HD, 420HD,
430HD, 440HD**

SNOM:

D315, D375, D765

YEALINK:

**T18P, T19P, T22P,
T28P, T46G, VP530**



DELTAPATH UC—擁有更 多的功能和更好體驗

We bring the communication journey a leap forward

DELTAPATH支持DOLBY VOICE---大大增強通信體驗

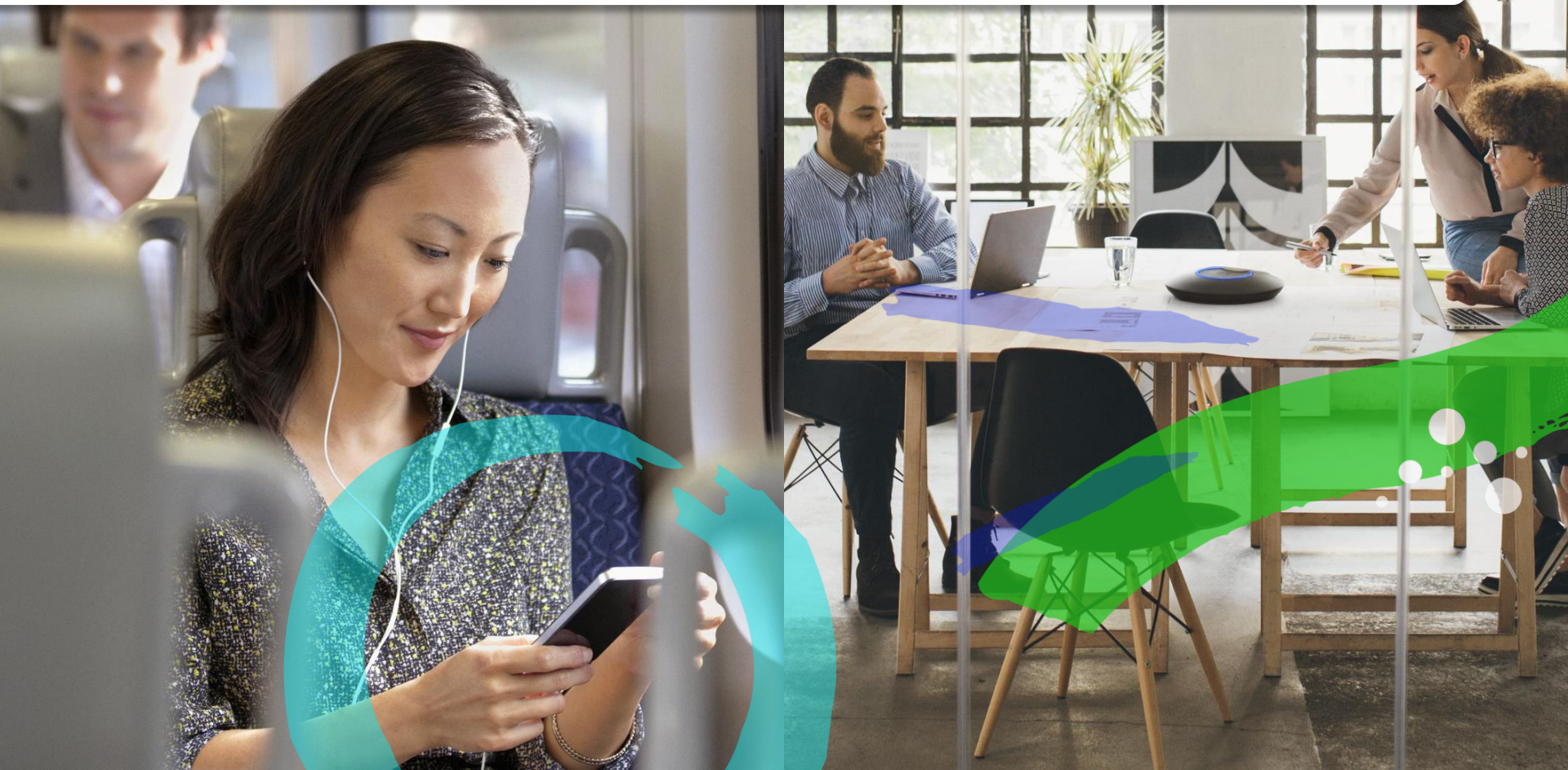

功能強大的移動APP: DELTAPATH MOBILE

Send text messages,
videos and images

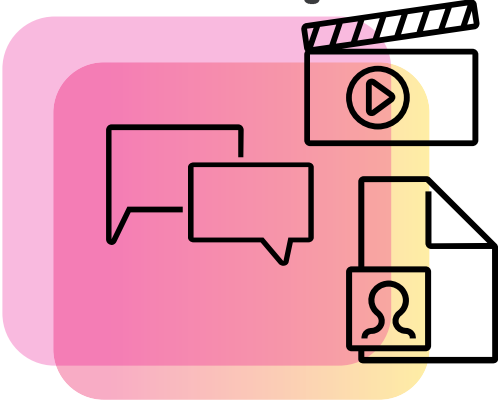

Pickup calls for
your colleagues

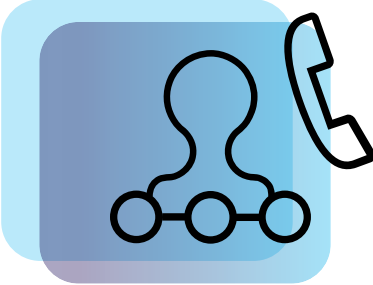

Invite participants
to a meeting

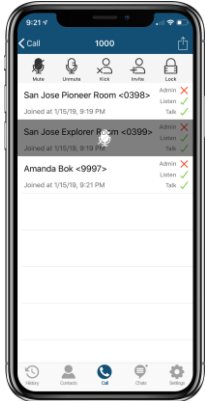
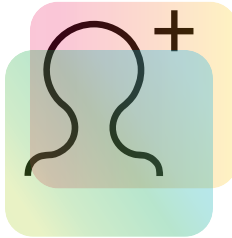

Forward your calls

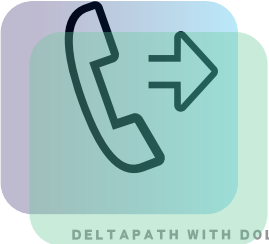

Turn on video calls



All smart
devices will ring

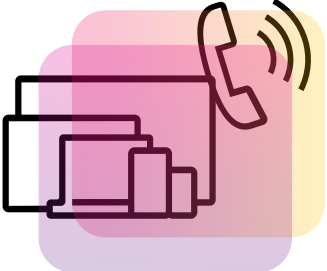

DELTAPATH WITH DOLBY VOICE

功能列表



Audio Conference Bridge



IP Phone



Voice/Video Mail,
Fax to Email, E-Fax



Intelligent
Interactive Voice
Responding



Self Service Portal



Mobile Apps on
iOS / Android



Video Conferencing



Call Recording



Inbound/Outbound
Call Center



Service
Provider Billing
System



Enterprise IM



Alarm
Notification



Push to Talk



CRM Integration



SFB
Integration

目錄

1. Deltapath和Cisco

2. 逐步遷移

3. 一次性

現在

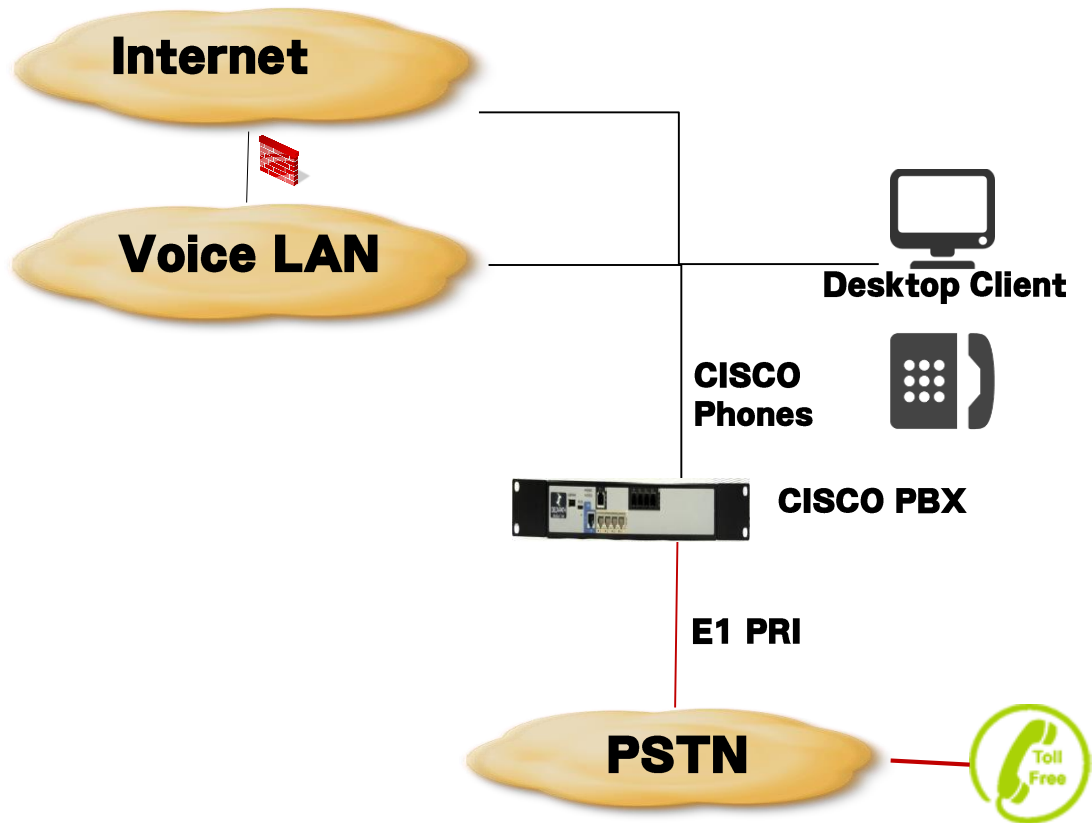

Deltapath UC和Cisco CUCM共存

—提供降噪功能和手機APP功能

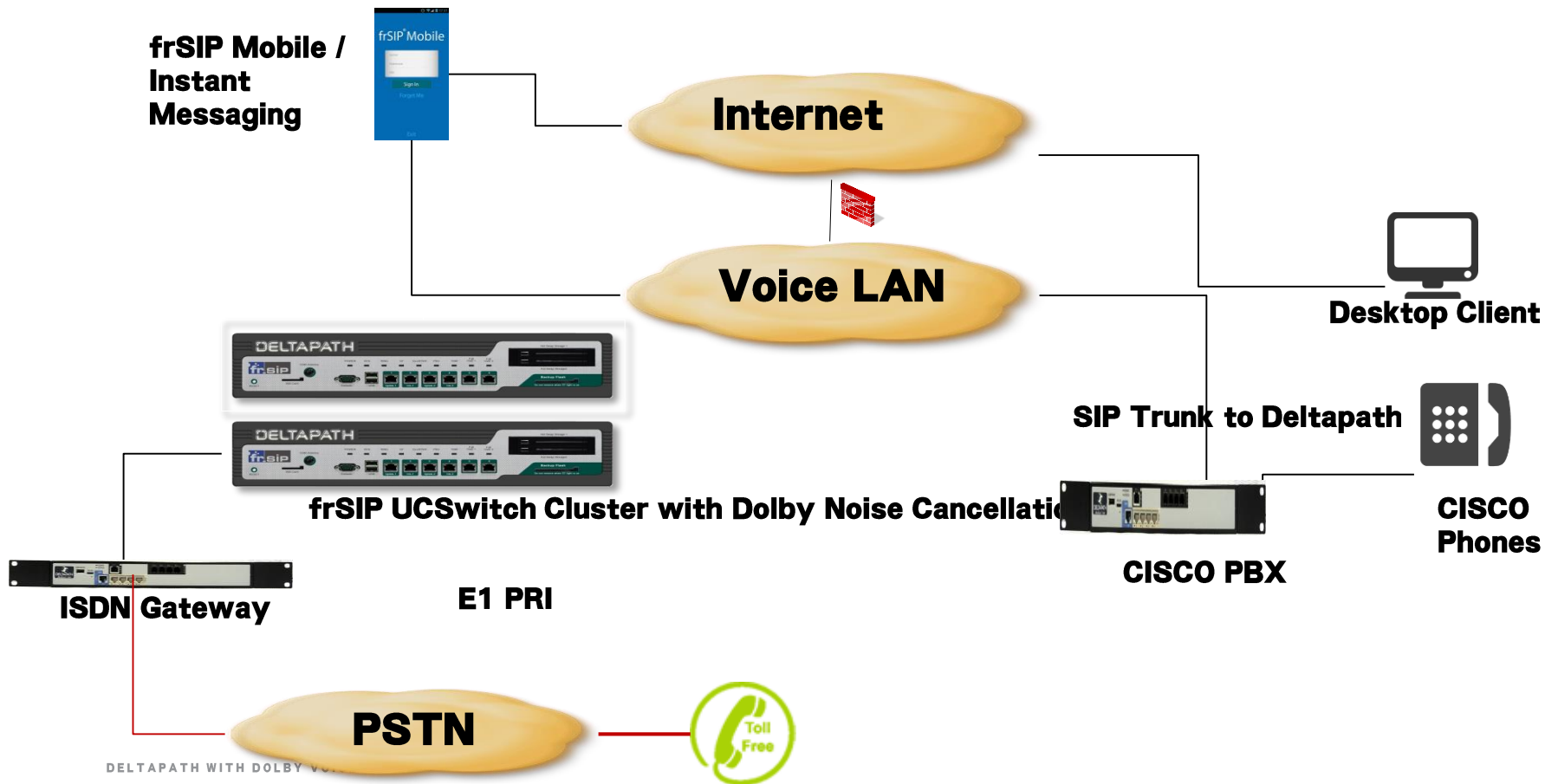

從Cisco遷移到Deltapath UC

frSIP Mobile /
Instant
Messaging

CISCO Phones



Desktop Client

New SIP Phones



frSIP UC Switch Cluster with Dolby Noise Cancellation

ISDN Gateway



E1 PRI



目錄

1.Deltapath和Cisco

2.逐步遷移

3.一次性



CUCM 免費升級計劃

**EXPERIENCE WHAT THE COMMUNICATION
OF THE FUTURE CAN DO FOR YOU**

ENTER NAME (OPTIONAL)

ENTER TITLE (OPTIONAL)

不增加任何費用

It's like being gifted a new house for life and all you have to do is pay property tax and management fees. No mortgage or rent ever!

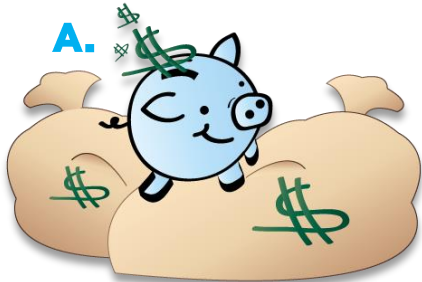

DELTAPATH WITH DOLBY VOICE



Inbound/Outbound Call Center



Enterprise IM



IP Phone



Voice/Video Mail, Fax to Email, E-Fax



Self Service Portal



Call Recording



Mobile Apps on iOS / Android



Intelligent Interactive Voice Responding



Push to Talk



Alarm Notification



Audio Conference Bridge



Video Conferencing



SFB Integration



Service Provider Billing System

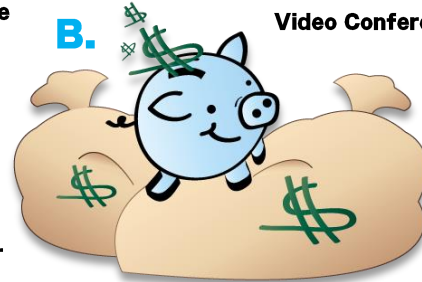

CRM Integration

流程



Show your current Cisco annual maintenance bill.



Show your current CUCM installed license summary.



Provide your current voice infrastructure inventory/Bill of Material to ensure compatibility.



Define your migration plan. Big Bang vs Parallel. Reboot phones and migrate PRI over.



Deltapath will deliver appliances* and gateways that match with your current (BOM).*



Sign paperwork.

You have been upgraded!



如何實現

Hybrid Private Cloud Model

- **Total Control by customer within their network.**
- **Simple annual subscription fee.**
- **Data hosted on premise at customer location.**
- **Survivable from cloud vendor or Internet outages**



READINESS



SCALE



ALL-IN-ONE SOLUTION



REDUCE AND SIMPLIFY



QUALITY



DATA SOVEREIGNTY



AVAILABILITY &
MONITORING



FLEXIBILITY



SECURITY

QUALIFYING QUESTIONS

First Question: ARE YOU A CUCM CUSTOMER?

Why should I change asks the customer?

Do you have EOL Cisco endpoints or a legacy Call Manager?

Are you interested in protecting your Cisco investment or upgrading to Dolby Voice PBX/UC?

Yes. Are you interested in upgrading your Call Manager for free while keeping your legacy Cisco endpoints?

No. Would you be interested in upgrading your Call Manager for free to support Dolby Voice?

What to Pitch

Cisco charges you an upgrade fee and once upgraded you can no longer use your older endpoints. We can help you extend the life of your endpoints while offering you new features such as Dolby Voice.

Pitch how Dolby Voice solves conference and phone call challenges without ever increasing your annual budget. Just pay us what you pay Cisco today for annual maintenance and you get an upgraded system for free.

回顧整個PROGRAM的流程

(OPTIONAL SLIDE IF YOU WANT TO SUMMARIZE MAIN POINTS A THE END)

- 1. Understand CUCM customers pain points - Version customer is using is too old, Phones are EOL, New requirements and features are not supported such as call center, mobility, or SFB interop**
- 2. Request a Cisco maintenance invoice from the customer**
 - **If annual maintenance <US \$7,000, offer Deltapath Virtual Edition**
 - **If annual maintenance >US \$7,000, offer Deltapath Appliance**
- 3. Customers pay Deltapath exactly what they are paying Cisco today, but get to enjoy a new system based on a subscription**
- 4. All existing Cisco license features purchased by Customer will be honored plus the customer will receive the Dolby Voice upgrade for free with the opportunity to add-on many other services**

請按照如下步驟,開始行動

(OPTIONAL SLIDE. SEE EXAMPLES BELOW OF HOW YOU CAN USE THE SLIDE

- **Offer 1 month free PoC onsite and help customers migrate some Cisco users to Deltapath UC PoC platform**
- **Deltapath engineer provides remote support to setup the PoC and let customers start testing (Clearly define the test items).**
- **Review the PoC once completed and proceed to commercial/ordering.**
- **Distribution partner will earn a gross margin of xx% on recurring basis plus any VAR professional services**

舉例 — 大型客戶

(Optional Slide to provide specifics about a large install base)

- **Customer pays \$8,500 to Cisco annually**
- **CUCM license contains: 500 users, voicemail, and meet me conference, with redundant server**
- **Customer pays \$8,500 to partner or its VAR**
- **Deltapath will deliver 2 units of Deltapath appliance with 500 user license with free mobility app, voicemail, Dolby Voice Audio Conference, and Dolby Voice module**
- **Partner pays Deltapath annually in advance \$xxxx**
- **Partner and VAR charges for optional onsite training and migration \$xxxx**

舉例—中小客戶

(OPTIONAL SLIDE TO PROVIDE SPECIFICS ABOUT A SMALL INSTALL BASE)

- **Customer pays \$4,000 to Cisco annually.**
- **CUCM license contains: 100 users, voicemail, no cluster**
- **Customer pays \$4,000 to partner or its VAR**
- **Deltapath will issue a virtual edition license with 100 users license and free mobility app, voicemail, and Dolby Voice.**
- **Partner or VAR assist with installation of virtual edition on customer VM Hypervisor (VMWare ESXi or Microsoft Hyper-V)**
- **Partner pays Deltapath annually in advance \$xxxx**
- **Partner / VAR charges \$xxxx for onsite training and migration service**

案例分享: 亞洲航空



- **AirAsia is the leading low-cost carrier of Asia**
- **Deployed Deltapath Connector to:**
 - Centrally manage all Cisco SX video endpoints**
 - Extension to extension dialing**
 - Call to PSTN right from the video conferencing systems.**
- **After deployment, started upselling**
 - Migrated 2000 enterprise PBX users to Deltapath UC**
 - Migrated 200 call center queues and agents to Deltapath UC with Cinch Contact Center and Salesforce.com integration.**

**The communication platform that enables
organizations to work smarter**

